

KX -PFA130-E

Water-proof Junction Box



Features

Neat & Integrated design

Material: Aluminum

IP66 junction box

Camera Mount Series | KX -PFA130-E

Technical Specifications

Model	KX -PFA130-E
General	
Material	Aluminum
Dimension	Φ124mmx41mm(φ4.88"x1.61")
Pipe thread	G3/4"
Weight	0.35kg(0.77lb)
Load bearing	3.0kg(6.61lb)
Color	White
Protection	IP66
Operating temperature	-40°C ~60°C(-40 ~+140)
Humidity	< 90% RH
Applicable model	Please see "Accessory Selection"

Order Information

Type	Part Number	Description
Camera mount	KX -PFA130-E	Water-proof junction box
	PFA130-E	Water-proof junction box

Dimensions (mm /inch)

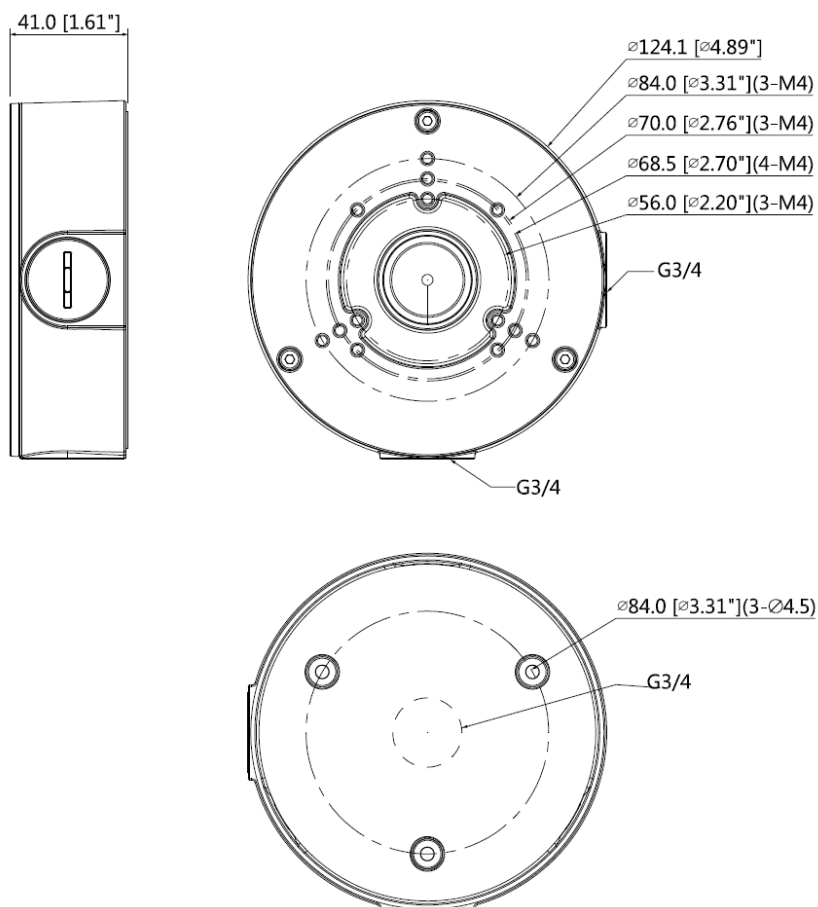

Application

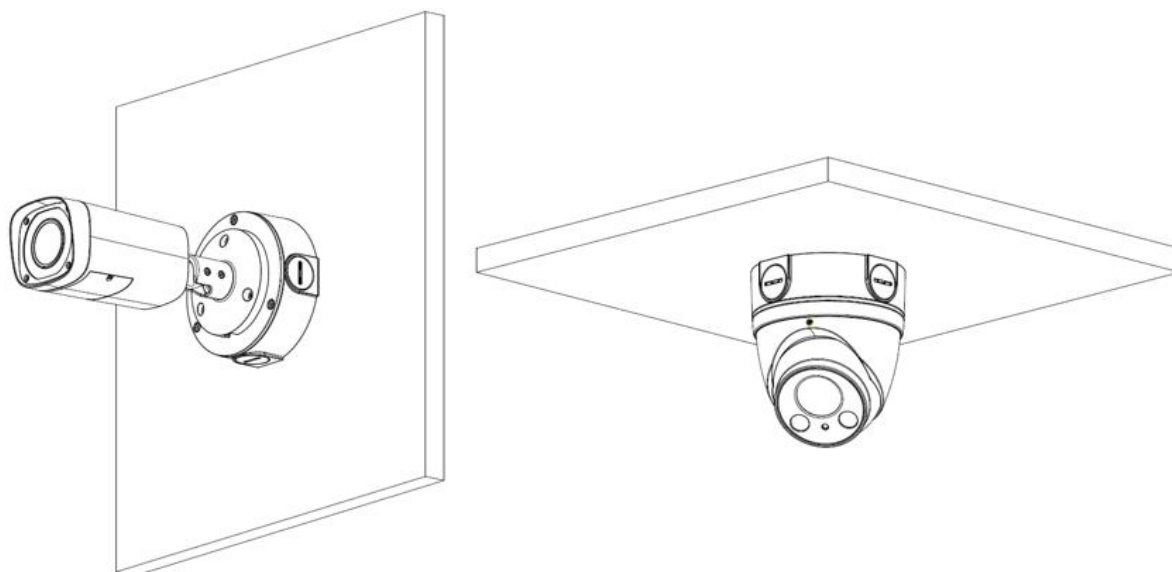

Package Information

Water -proof junction box KX -PFA130-E *1

M4x10 screw *4

ST4.2x25 screw *3

Plastic Anchor: 3

Mounting sticker *1

S3.0 wrench *1